

CBSE Class 10 Maths Paper Solution

General Instructions:

- (i) All questions are compulsory.
- (ii) The question paper consists of 34 questions divided into four sections A, B, C and D.
- (iii) Section A contains 8 questions of one mark each, which are multiple choice type questions, section B contains 6 questions of two marks each, section C contains 10 questions of three marks each, and section D
- (iv) Use of calculators is not permitted.

Q1

The common difference of the AP $\frac{1}{p}, \frac{1-p}{p}, \frac{1-2p}{p}, \dots$ can be found out by finding the difference between the second term and first term i.e. $\frac{1-p}{p} - \frac{1}{p} = \frac{1-p-1}{p} = \frac{-p}{p} = -1$

The correct answer is -1 which is given by option C.

Q2

Since, $AP \perp PB$, $CA \perp AP$, $CB \perp BP$ and $AC = CB = \text{radius of the circle}$, therefore APBC is a square having side equal to 4 cm.

Therefore, length of each tangent is 4 cm.

The correct answer is 4 cm which is given by option B.

Q3

Given that AB, BC, CD and AD are tangents to the circle with centre O at Q, P, S and R respectively. $AB = 29$ cm, $AD = 23$, $DS = 5$ cm and $\angle B = 90^\circ$.

Join PQ.

We know that, the lengths of the tangents drawn from an external point to a circle are equal.

$$DS = DR = 5 \text{ cm}$$

$$\therefore AR = AD - DR = 23 \text{ cm} - 5 \text{ cm} = 18 \text{ cm}$$

$$AQ = AR = 18 \text{ cm}$$

$$\therefore QB = AB - AQ = 29 \text{ cm} - 18 \text{ cm} = 11 \text{ cm}$$

$$QB = BP = 11 \text{ cm}$$

$$\text{In right } \triangle PQB, PQ^2 = QB^2 + BP^2 = (11 \text{ cm})^2 + (11 \text{ cm})^2 = 2 \times (11 \text{ cm})^2$$

$$PQ = 11\sqrt{2} \text{ cm} \dots (1)$$

In right $\triangle PQB$,

$$PQ^2 = OQ^2 + OP^2 + r^2 + r^2 = 2r^2$$

$$PQ = \sqrt{2r} \dots (2)$$

From (1) and (2), we get

$$r = 11 \text{ cm}$$

thus, the radius of the circle is 11 cm.

The correct answer is **11** which is given by option **A**.

Q4

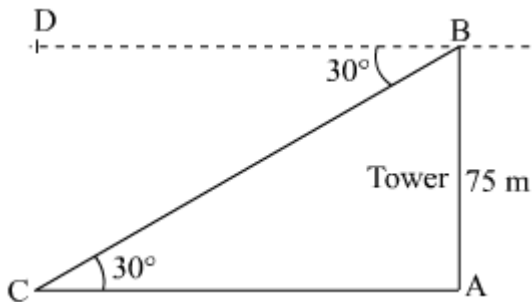

Let AB be the tower of height 75 m.

$$\angle CBD = \angle ACB = 30^\circ$$

Suppose C be the position of the car from the base of the tower.

In right $\triangle ABC$,

$$\cot 30^\circ = \frac{AC}{AB}$$

$$\Rightarrow AC = AB \cot 30^\circ$$

$$\Rightarrow AC = 75 \text{ m} \times \sqrt{3}$$

$$\Rightarrow AC = 75\sqrt{3} \text{ m}$$

Thus, the distance of the car from the base of the tower is $75\sqrt{3}$ m.

The correct answer is $75\sqrt{3}$ which is given by option C.

Q5

When a die is thrown once, the sample space is given by, $S = \{1,2,3,4,5, \text{ and } 6\}$

Then, the event, E of getting an even number is given by, $E = \{2,4, \text{ and } 6\}$

$$\therefore \text{Probability of getting an even number} = P(E) \therefore P(E) = \frac{\text{Number of favourable outcomes}}{\text{Number of all possible outcomes}} = \frac{3}{6} = \frac{1}{2}$$

The correct answer is $\frac{1}{2}$ which is given by option A.

Q6

If the given that the box contains 90 discs, numbered from 1 to 90.

As one disc is drawn at random from the box, the sample space is given by, $S = \{1,2,3,\dots,90\}$

The prime number less than 23 are 2,3,5,7,11,13,17, and 19.

Then, the event, E of getting a prime number is given by, $E = \{2,3,5,7,11,13,17,19\}$

$$\therefore P(E) = \frac{\text{Number of favourable outcomes}}{\text{Number of all possible outcomes}} = \frac{8}{90} = \frac{4}{45}$$

The correct answer is $\frac{4}{45}$ which is given by option C.

Q7

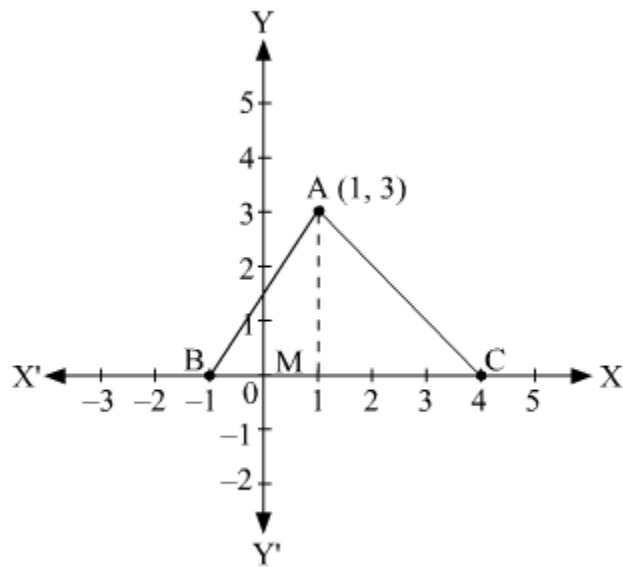

Construction : Draw $AM \perp BC$.

It can be observed from the given figure that $BC = 5$ unit and $AM = 3$ unit.

In $\triangle ABC$, BC is the base and AM is the height.

Area of triangle $ABC = \frac{1}{2} \times \text{base} \times \text{height}$

$$= \frac{1}{2} \times BC \times AM$$

$$= \frac{1}{2} \times 5 \times 3 \text{ sq. units}$$

$$= 7.5 \text{ sq. units}$$

The correct answer is **7.5** which is given by option **C**.

Q8

Difference between circumference and radius of the circle = 37 cm

Let r be the radius of the circle.

$$\therefore 2\pi r - r = 37 \text{ cm}$$

$$\begin{aligned} \Rightarrow r(2\pi - 1) &= 37 \text{ cm} \\ \Rightarrow r\left(2 \times \frac{22}{7} - 1\right) &= 37 \text{ cm} \\ \Rightarrow r \times \frac{37}{7} &= 37 \text{ cm} \\ \Rightarrow r &= 7 \text{ cm} \end{aligned}$$

$$\therefore \text{Circumference of the circle} = 2\pi r = 2 \times \frac{22}{7} \times 7 \text{ cm} = 44 \text{ cm}$$

The correct answer is **44** which is given by option **B**.

Q9

$$\begin{aligned} 4\sqrt{3x^2} + 5x - 2\sqrt{3} &= 0 \\ \Rightarrow 4\sqrt{3}x^2 + 8x - 3x - 2\sqrt{3} &= 0 \\ \Rightarrow 4x(\sqrt{3}x + 2) - \sqrt{3}(\sqrt{3} + 2) &= 0 \\ \Rightarrow (4x - \sqrt{3})(\sqrt{3}x + 2) &= 0 \\ \therefore x = \frac{\sqrt{3}}{4} \text{ or } x = -\frac{2}{\sqrt{3}} \end{aligned}$$

Q10

All the three-digit natural numbers that are divisible by 7 will be of the form $7n$.

$$\text{Therefore, } 100 \leq 7n \leq 999 \Rightarrow 14\frac{2}{7} \leq n \leq 142\frac{5}{7}$$

Since, n is an integer, therefore, there will be $142 - 14 = 128$ three-digit natural numbers that will be divisible by 7.

Therefore, there will be 128 three – digit natural numbers that will be divisible by 7.

Q11

Given that $AB = 12 \text{ cm}$, $BC = 8 \text{ cm}$ and $AC = 10 \text{ cm}$.

Let, $AD = AF = p \text{ cm}$, $BD = BE = q \text{ cm}$ and $CE = CF = r \text{ cm}$

(Tangents drawn from an external point to the circle are equal in length)

$$\begin{aligned} \Rightarrow 2(p + q + r) &= AB + BC + AC = AD + DB + BE + EC + AF + FC = 30 \text{ cm} \\ \Rightarrow p + q + r &= 15 \\ AB = AD + DB &= p + q = 12 \text{ cm} \end{aligned}$$

Therefore, $r = CF = 15 - 12 = 3 \text{ cm}$.

$$AC = AF + FC = p + r = 10 \text{ cm}$$

Therefore, $q = BE = 15 - 10 = 5 \text{ cm}$.

Therefore, $p = AD = p + q + r - r - q = 15 - 3 - 5 = 7 \text{ cm}$.

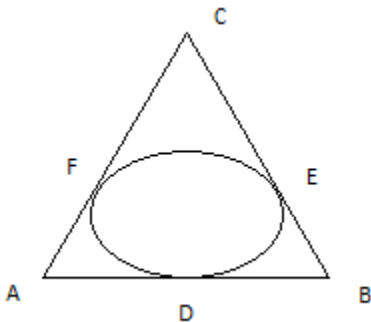

Q12.

GIVEN : ABCD be a parallelogram circumscribing a circle with centre O.

TO PROVE : ABCD is a rhombus.

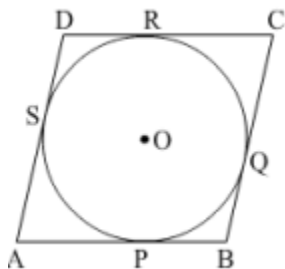

We know that the tangents drawn to a circle from an exterior point are equal in length.

Therefore, $AP = AS$, $BP = BQ$, $CR = CQ$ and $DR = DS$.

$$AP + BP + CR + DR = AS + BQ + CQ + DS$$

$$(AP + BP) + (CR + DR) = (AS + DS) + (BQ + CQ)$$

Therefore, $AB + CD = AD + BC$ or $2AB = 2BC$ (Since, $AB = DC$ and $AD = BC$)

Therefore, $AB = BC = DC = AD$.

Therefore, ABCD is a rhombus.

Hence, proved.

Q13

Let E denote the event that the drawn card is neither a king nor a queen.

Total number of possible cases = 52.

Total number of cards that are king and those that are queen in the pack of playing cards = 4 + 4 = 8.

Therefore, there are 52-8 = 44 cards that are neither a king nor a queen.

Total number of favorable cases = 44.

$$\therefore \text{Required probability} = P(E) = \frac{\text{Favourable number of cases}}{\text{Total number of cases}} = \frac{44}{52} = \frac{11}{13}$$

Thus, the probability that the drawn card is neither a king nor a queen is $\frac{11}{13}$.

Q14

Dimension of the rectangular card board = 14 cm x 7 cm

Since, two circular pieces of equal radii and maximum area touching each other are cut from the rectangular card board, therefore, the diameter of each of each circular piece is 14/2 = 7 cm.

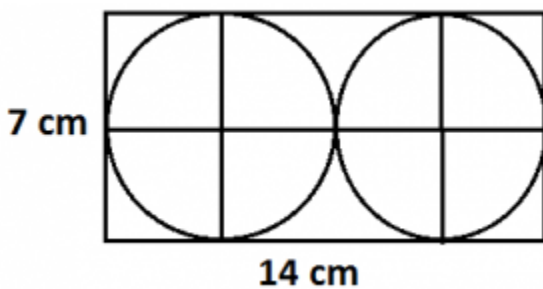

Radius of each circular piece = $\frac{7}{2}$ cm.

$$\therefore \text{Sum of area of two circular pieces} = 2 \times \pi \left(\frac{7}{2}\right)^2 = 2 \times \frac{22}{7} \times \frac{49}{4} = 77 \text{ cm}^2$$

Area of the remaining card board = Area of the card board – Area of two circular pieces

$$= 14 \text{ cm} \times 7 \text{ cm} - 77 \text{ cm}^2 = 98 \text{ cm}^2 - 77 \text{ cm}^2 = 21 \text{ cm}^2$$

Thus, the area of the remaining card board is 21 cm².

Q15

The given quadratic equation is $kx(x - 2) + 6 = 0$.

This equation can be rewritten as $kx^2 - 2kx + 6 = 0$.

For equal roots, its discriminant, $D = 0$.

$$\Rightarrow b^2 - 4ac = 0, \text{ where } a = k, b = -2k \text{ and } c = 6$$

$$\Rightarrow 4k^2 - 24k = 0$$

$$\Rightarrow 4k(k - 6) = 0$$

$$\Rightarrow k = 0 \text{ or } k = 6$$

But k cannot be 0, so the value of k is **6**.

Q16

The AP is given as $18, 15\frac{1}{2}, 13, \dots, -49\frac{1}{2}$.

First term $a = 18$, common difference $d = 15\frac{1}{2} - 18 = -2\frac{1}{2}$ and the last term of the AP = $-49\frac{1}{2}$.

Let the AP has n terms.

$$a_n = a + (n-1)d$$

$$-99/2 = 18 - (5/2)(n-1)$$

$$5(n-1) = 135$$

$$n = 27 + 1$$

$$n = 28$$

$$\therefore n = 27 + 1 = 28$$

Thus, the given AP has **28** terms.

Now, the sum of all the terms (S_n) is given by,

$$S_n = \frac{n}{2} [2a + (n-1)d] = \frac{28}{2} [2 \times 18 + (28 - 1) \times \left(-\frac{5}{2}\right)] = 14 [36 - 27 \times \frac{5}{2}] = -441$$

Thus, the sum of all the terms of the AP is **-441**.

Q17

Step 1

Draw a line segment $AB = 4$ cm. taking point A as centre, draw an arc of 5 cm radius.

Similarly, taking point B as its centre, draw an arc of 6 cm radius. These arcs will intersect each other at point C. Now, $AC = 5$ cm and $BC = 6$ cm and $\triangle ABC$ is the required triangle.

Step 2

Draw a ray AX making an acute angle with line AB on the opposite side of vertex C.

Step 3

Locate 3 points A_1, A_2, A_3 (as 3 is greater between 2 and 3) on line AX such that

$$AA_1 = A_1A_2 = A_2A_3.$$

Step 4

Join BA_3 and draw a line through A_2 parallel to BA_3 to intersect AB at point B' .

Step 5

Draw a line through B' parallel to the line BC to intersect AC at C' .

$\triangle AB'C'$ is the required triangle.

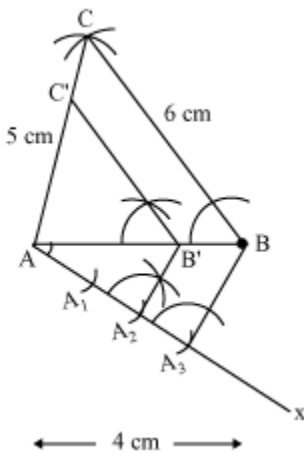

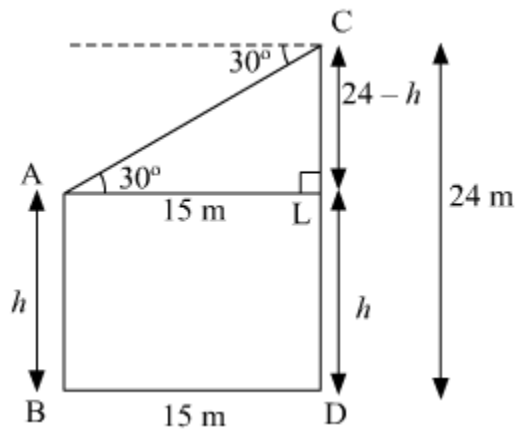

Let AB and CD be two poles, where $CD = 24$ m.

It is given that angle of depression of the top of the pole AB as seen from the top of the pole CD is 30° and horizontal distance between the two poles is 15 m.

$\therefore \angle CAL = 30^\circ$ and $BD = 15$ m.

To find: height of pole AB

Let the height of pole AB be h m.

$AL = BD = 15$ m and $AB = LD = h$

Therefore, $CL = CD - LD = 24 - h$

Consider right $\triangle ACL$:

$$\tan \angle CAL = \frac{\text{Perpendicular}}{\text{Base}} = \frac{CL}{AL}$$

$$\Rightarrow \tan 30^\circ = \frac{24-h}{15}$$

$$\Rightarrow \frac{1}{\sqrt{3}} = \frac{24-h}{15}$$

$$\Rightarrow 24 - h = \frac{15}{\sqrt{3}}$$

$$\Rightarrow 24 - h = 5\sqrt{3}$$

$$\Rightarrow h = 24 - 5\sqrt{3}$$

$$\Rightarrow h = 24 - 5 \times 1.732 \text{ [Taking } \sqrt{3} = 1.732 \text{]}$$

$$\Rightarrow h = 15.34$$

Therefore, height of the pole AB = h m = **15.34 m**.

Q19

Let the given points be A (7,10) B(-2,5) and C(3,-4).

Using distance formula, we have

$$AB = \sqrt{(7 + 2)^2 + (10 - 5)^2} = \sqrt{81 + 25} = \sqrt{106}$$

$$BC = \sqrt{(-2 - 3)^2 + (5 + 4)^2} = \sqrt{25 + 81} = \sqrt{106}$$

$$CA = \sqrt{(7 - 3)^2 + (10 + 4)^2} = \sqrt{16 + 196} = \sqrt{212}$$

Since $AB = BC$, therefore, $\triangle ABC$ is an isosceles triangle.

$$\text{Also, } AB^2 + BC^2 = 106 + 106 = 212 = AC^2$$

So, $\triangle ABC$ is a right triangle right angled at $\angle B$.

So, $\triangle ABC$ is an isosceles triangle as well as a right triangle.

Thus, the points (7, 10), (-2, 5) and (3,-4) are the vertices of an isosceles right triangle.

Q20

Let the y-axis divide the line segment joining the points (-4,-6) and (10,12) in the ratio $\lambda : 1$ and the

Point of the intersection be (0,y).

So, by section formula, we have:

$$\left(\frac{10\lambda + (-4)}{\lambda + 1}, \frac{12\lambda + (-6)}{\lambda + 1} \right) = (0, y)$$

$$\therefore \frac{10\lambda - 4}{\lambda + 1} = 0 \Rightarrow 10\lambda - 4 = 0$$

$$\Rightarrow \lambda = \frac{4}{10} = \frac{2}{5}$$

$$\text{Therefore, } y = \frac{12\lambda + (-6)}{\lambda + 1} = \frac{12 \times \frac{2}{5} - 6}{\frac{2}{5} + 1} = \frac{\left(\frac{24-30}{5}\right)}{\left(\frac{2+5}{5}\right)} = -\frac{6}{7}$$

Thus, the y-axis divides the line segment joining the given points in the ratio 2 : 5 and the point of division is $(0, -\frac{6}{7})$.

Q21

AB and CD are the diameters of a circle with centre O.

Therefore, OA = OB = OC = OD = 7 cm (Radius of the circle)

Area of the shaded region

= Area of the circle with diameter OB + (Area of the semi-circle ACDA – Area of $\triangle ACD$)

$$= \pi \left(\frac{7}{2}\right)^2 + \left(\frac{1}{2} * \pi * (7)^2 - \frac{1}{2} * 14 \text{ cm} * 7 \text{ cm}\right)$$

$$= \frac{22}{7} * \frac{49}{4} \text{ cm}^2 + \frac{1}{2} * \frac{22}{7} * 49 \text{ cm}^2 - \frac{1}{2} * 14 \text{ cm} * 7 \text{ cm}$$

$$= \frac{77}{2} \text{ cm}^2 + 77 \text{ cm}^2 - 49 \text{ cm}^2$$

$$= 66.5 \text{ cm}^2$$

Thus, the area of the shaded region is 66.5 cm².

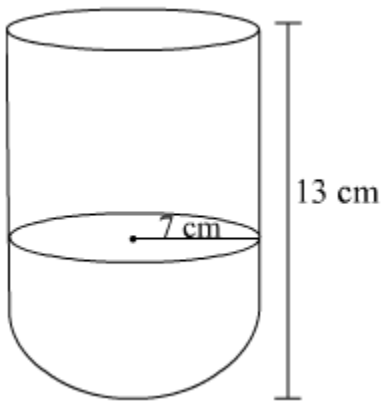
Q22

Let the radius and height of cylinder is r cm and h cm respectively.

Diameter of the hemispherical bowl = 14 cm

$$\therefore \text{Radius of the hemispherical bowl} = \text{Radius of the cylinder} = r = \frac{14}{2} \text{ cm} = 7 \text{ cm}$$

Total height of the vessel = 13 cm

\therefore Height of the cylinder, h = Total height of the vessel – Radius of the hemispherical bowl

$$= 13 \text{ cm} - 7 \text{ cm} = 6 \text{ cm}$$

Total surface area of the vessel = 2 (curved surface area of the cylinder + curved surface area of the hemisphere) (Twice because the vessel is hollow)

$$= 2(2\pi rh + 2\pi r^2) = 4\pi r(h+r) = 4 \times \frac{22}{7} \times 7 \times (6+7)\text{cm}^2$$

$$= 1144 \text{ cm}^2$$

Thus, the total surface area of the vessel is 1144 cm².

Q23

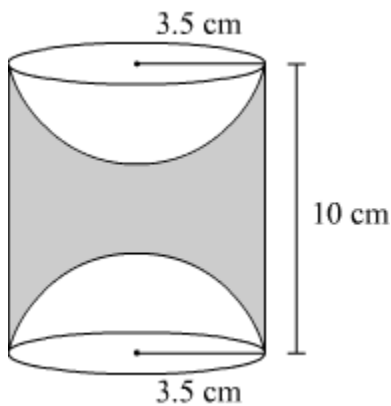

Height of the cylinder, $h = 10 \text{ cm}$

Radius of the cylinder = Radius of each hemisphere = $r = 3.5 \text{ cm}$

Volume of wood in the toy = Volume of the cylinder – 2 x Volume of each hemisphere

$$= \pi r^2 h - 2 \times \frac{2}{3} \pi r^3$$

$$= \frac{22}{7} \times (3.5 \text{ cm})^2 \times 10 \text{ cm} - \frac{4}{3} \times \frac{22}{7} \times (3.5 \text{ cm})^3$$

$$= 385 \text{ cm}^3 - \frac{539}{3} \text{ cm}^3$$

$$= \frac{616}{3} \text{ cm}^3$$

$$= 205.33 \text{ cm}^3 \text{ (Approx)}$$

Thus, the volume of the wood in the toy is approximately 205.33 cm³.

Q24

It is given that, radius = 21 cm.

The Arc subtends an angle of 60° .

(i) length (l) of the arc is given by : 360°

$$l = \frac{\theta}{360^\circ} \times 2\pi r, \text{ where } r = 21 \text{ cm and } \theta = 60^\circ$$

$$= \frac{60}{360} \times 2 \times \frac{22}{7} \times 21 \text{ cm}$$

$$= 22 \text{ cm}$$

(ii) Area, A of the sector formed by the arc is given by

$$A = \frac{\theta}{360^\circ} \times \pi r^2, \text{ where } r = 21 \text{ cm and } \theta = 60^\circ$$

$$= \frac{60^\circ}{360^\circ} \times \frac{22}{7} \times 21 \times 21 \text{ cm}^2$$

$$= 231 \text{ cm}^2$$

Q25

The given equation is $\frac{1}{2a+b+2x} = \frac{1}{2a} + \frac{1}{b} + \frac{1}{2x}$

$$\frac{1}{2a+b+2x} = \frac{1}{2a} + \frac{1}{b} + \frac{1}{2x}$$

$$\Rightarrow \frac{1}{2a+b+2x} - \frac{1}{2x} = \frac{1}{2a} + \frac{1}{b}$$

$$\Rightarrow \frac{2x-2a-b-2x}{2x(2a+b+2x)} = \frac{b+2a}{2ab}$$

$$\Rightarrow \frac{-2a-b}{2x(2a+b+2x)} = \frac{b+2a}{2ab}$$

$$\Rightarrow \frac{-(2a+b)}{2x(2a+b+2x)} = \frac{b+2a}{2ab}$$

$$\Rightarrow \frac{-1}{x(2a+b+2x)} = \frac{1}{ab}$$

$$\Rightarrow 2x^2 + 2ax + bx + ab = 0$$

$$\Rightarrow 2x(x+a) + b(x+a) = 0$$

$$\Rightarrow (x+a)(2x+b) = 0$$

$$\Rightarrow x+a = 0 \text{ or } 2x+b = 0$$

$$\Rightarrow x = -a, \text{ or } x = \frac{-b}{2}$$

Q26 let the sides of the two squares be x cm and y cm where $x > y$.

Then, their areas are x^2 and y^2 and their perimeters are $4x$ and $4y$.

By the given condition, $x^2 + y^2 = 400$ and $4x - 4y = 16$

$$4x - 4y = 16 \Rightarrow 4(x - y) = 16 \Rightarrow x - y = 4$$

$$\Rightarrow x = y + 4 \dots(1)$$

Substituting the value of y from (1) in $x^2 + y^2 = 400$, we get that $(y+4)^2 + y^2 = 400$

$$\Rightarrow y^2 + 16 + 8y + y^2 = 400$$

$$\Rightarrow y^2 + 4y - 192 = 0$$

$$\Rightarrow y^2 + 16y - 12y - 192 = 0$$

$$\Rightarrow y(y+16) - 12(y+16) = 0$$

$$\Rightarrow (y+16)(y-12) = 0$$

$$\Rightarrow y = -16 \text{ or } y = 12$$

since, the value of y cannot be negative, the value of $y = 12$.

$$\text{So, } x = y+4 = 12+4 = 16$$

Thus, the sides of the two squares are 16 cm and 12 cm.

Q27

Given that, $S_7 = 49$ and $S_{17} = 289$

$$S_n = \frac{n}{2} [2a + (n-1)d]$$

$$\therefore S_7 = 49 = \frac{7}{2} [2a + (7-1)d] \Rightarrow 49 = \frac{7}{2} (2a + 6d)$$

$$\Rightarrow (a + 3d) = 7 \dots\dots(i)$$

$$\text{Similarly, } S_{17} = \frac{17}{2} [2a + (17-1)d]$$

$$\Rightarrow 289 = \frac{17}{2} [2a + 16d]$$

$$\Rightarrow (a + 8d) = 17 \dots\dots(ii)$$

Subtracting equation (i) from equation (ii), we get that $5d = 10$.

Therefore, the value of $d = 2$ and $a = 7 - 3d = 1$

$$\therefore S_n = \frac{n}{2} [2a + (n-1)d] = \frac{n}{2} [2(1) + (n-1)(2)]$$

$$= \frac{n}{2} (2+2n-2) = \frac{n}{2} (2n) = n^2$$

Therefore, the sum of n terms of the AP is n^2 .

Q28

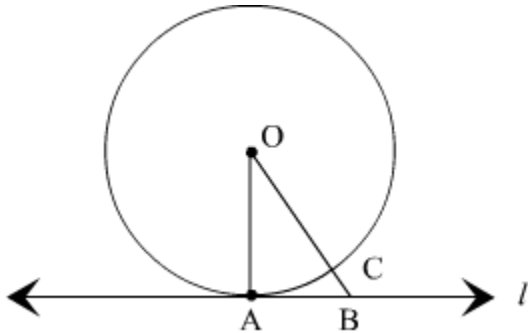

Given : A circle $C(O,r)$ and a tangent l at point A .

To prove : $OA \perp l$

Construction : take a point B , other than A , on the tangent l . Join OB . Suppose OB meets the circle in C .

Proof : we know that, among all line segment joining the point O to a point on l , the perpendicular is shortest to l .

$OA = OC$ (Radius of the same circle)

Now, $OB = OC + BC$.

Therefore, $OB > OC$

$\Rightarrow OB > OA$

$\Rightarrow OA > OB$

B is an arbitrary point on the tangent l . thus, OA is shorter than any other line segment joining O to any point on l .

Hence, proved.

Q29

Given : l and m are two parallel tangents to the circle with centre O touching the circle at A and B respectively. DE is a tangent at the point C , which intersects l at D and m at E .

To prove : $\angle DOE = 90^\circ$

Construction : Join OC .

Proof :

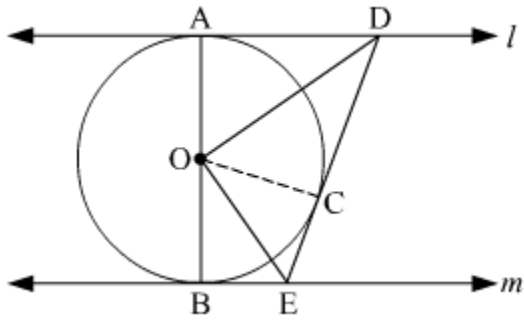

In $\triangle ODA$ and $\triangle ODC$,

$OA = OC$ (Radii of the same circle)

$AD = DC$ (Length of tangents drawn from an external point to a circle are equal)

$DO = OD$ (Common side)

$\triangle ODA \cong \triangle ODC$ (SSS congruence criterion)

$\therefore \angle DOA = \angle COD \dots(1)$ (C.P.C.T)

Similarly, $\triangle OEB \cong \triangle OEC$

$\angle EOB = \angle COE \dots(2)$

AOB is a diameter of the circle. Hence, it is a straight line.

$\therefore \angle DOA + \angle COD + \angle COE + \angle EOB = 180^\circ$

From (1) and (2), we have

$$2 \angle COD + 2 \angle COE = 180^\circ$$

$$\Rightarrow \angle COD + \angle COE = 90^\circ$$

$$\Rightarrow \angle DOE = 90^\circ$$

Hence, proved.

Q30

Let AB be the building and CD be the tower. Suppose the height of the building be h m.

Given, $\angle ACB = 30^\circ$, $\angle CBD = 60^\circ$ and $CD = 60$ m

In right $\triangle BCD$:

$$\cot 60^\circ = \frac{BC}{CD} \Rightarrow BC = CD \cot 60^\circ$$

$$\Rightarrow BC = 60 \text{ m} * \frac{1}{\sqrt{3}} \Rightarrow BC = \frac{60}{\sqrt{3}} \text{ m} = \frac{60\sqrt{3}}{3} \text{ m} = 20\sqrt{3} \text{ m} \quad \dots(1)$$

In right $\triangle ACB$:

$$\tan 30^\circ = \frac{AB}{BC}$$

$$\Rightarrow \frac{1}{\sqrt{3}} = \frac{h}{20\sqrt{3}} \quad (\text{Using (1)})$$

$$\Rightarrow h = 20 \text{ m}$$

Thus, the height of the building is 20 m.

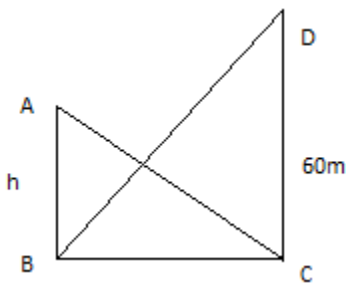

Q31

Since the group consists of 12 persons, sample space consists of 12 persons.

\therefore Total number of possible outcomes = 12

Let A denote event of selecting persons which are extremely patient

\therefore Number of outcomes favorable to A is 3.

Let B denote event of selecting persons which are extremely kind or honest.

Number of persons which are extremely honest is 6.

Number of persons which are extremely kind is $12 - (6+3) = 3$

\therefore Number of outcomes favorable to B = $6+3 = 9$.

(i) Probability of selecting a person who is extremely patient is given by P(A).

$$P(A) = \frac{\text{Number of outcomes favourable to A}}{\text{Total number of possible outcomes}} = \frac{3}{12} = \frac{1}{4}$$

(ii) Probability of selecting a person who is extremely kind or honest is given by P(B)

$$P(B) = \frac{\text{Number of outcomes favourable to B}}{\text{Total number of possible outcomes}} = \frac{9}{12} = \frac{3}{4}$$

Q32

The three vertices of the parallelogram ABCD are A(3,-4), B(-1,-3) and C(-6,2).

Let the coordinates of the vertex D be (x,y)

It is known that in a parallelogram, the diagonals bisect each other.

∴ Mid point of AC = Mid point of BD

$$\Rightarrow \left(\frac{3-6}{2}, \frac{-4+2}{2} \right) = \left(\frac{-1+x}{2}, \frac{-3+y}{2} \right)$$

$$\Rightarrow \left(-\frac{3}{2}, -\frac{2}{2} \right) = \left(\frac{-1+x}{2}, \frac{-3+y}{2} \right)$$

$$\Rightarrow -\frac{3}{2} = \frac{-1+x}{2}, -\frac{2}{2} = \frac{-3+y}{2}$$

$$\Rightarrow x = -2, y = 1$$

So, the coordinates of the vertex D is (-2,1).

Now, area of parallelogram ABCD

= area of triangle ABC + area of triangle ACD

= 2 x area of triangle ABC [Diagonal divides the parallelogram into two triangles of equal area]

The area of a triangle whose vertices are (x_1, y_1) , (x_2, y_2) and (x_3, y_3) is given by the numerical value of the expression $\frac{1}{2} [x_1(y_2 - y_3) + x_2(y_3 - y_1) + x_3(y_1 - y_2)]$

$$\text{Area of triangle ABC} = \frac{1}{2} [3(-3-2) + (-1)\{2-(-4)\} + (-6)\{-4-(-3)\}]$$

$$= \frac{1}{2} [3 * (-5) + (-1) * 6 + (-6) * (-1)] = \frac{1}{2} [-15-6+6] = -\frac{15}{2}$$

∴ Area of triangle ABC = $\frac{15}{2}$ sq units (Area of the triangle cannot be negative)

Thus, the area of parallelogram ABCD = $2 * \frac{15}{2} = 15$ sq units.

Q33

Diameter of circular end of pipe = 2 cm

∴ Radius (r_1) of circular end of pipe = $\frac{2}{200}$ m = 0.01 m.

$$\text{Area of cross-section} = \pi * r_1^2 = \pi * (0.01)^2 = 0.0001 \pi \text{ m}^2$$

Speed of water = 0.4 m/s = 0.4 * 60 = 24 metre/min

Volume of water that flows in 1 minute from pipe = 24 x 0.0001 π m³ = 0.0024 π m³

Volume of water that flows in 30 minute from pipe = $30 \times 0.0024 \pi \text{ m}^3 = 0.072 \pi \text{ m}^3$

Radius (r_2) of base of cylindrical tank = 40 cm = 0.4 m

Let the cylindrical tank be filled up to h m in 30 minutes.

Volume of water filled in tank in 30 minutes is equal to the volume of water flowed in 30 minutes from the pipe.

$$\therefore \pi * (r_2)^2 * h = 0.072 \pi$$

$$\Rightarrow (0.4)^2 * h = 0.072$$

$$\Rightarrow 0.16 * h = 0.072$$

$$h = \frac{0.072}{0.16}$$

$$\Rightarrow h = 0.45 \text{ m} = 45 \text{ cm}$$

Therefore, the rise in level of water in the tank in half an hour is 45 cm.

Q34

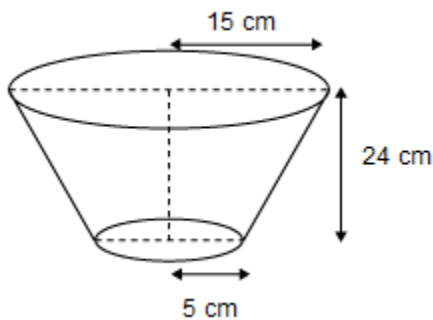

Diameter of upper end of bucket = 30 cm

\therefore Radius (r_1) of upper end of bucket = 15 cm

Diameter of lower end of bucket = 10 cm

\therefore Radius (r_2) of lower end of bucket = 5 cm

Height (h) of bucket = 24 cm

Slant height (l) of frustum = $\sqrt{(r_1 - r_2)^2 + h^2}$

$$= \sqrt{(15 - 5)^2 + (24)^2} = \sqrt{(10)^2 + (24)^2} = \sqrt{100 + 576}$$

$$= \sqrt{676} = 26 \text{ cm}$$

$$\begin{aligned}\text{Area of metal sheet used to make the bucket} &= \pi (r_1 + r_2)l + \pi r_2^2 = \pi (15 + 5)26 + \pi (5)^2 \\ &= 520\pi + 25\pi = 545 \pi \text{ cm}^2\end{aligned}$$

Cost of 100 cm^2 metal sheet = Rs 10

$$\text{Cost of } 545 \pi \text{ cm}^2 \text{ metal sheet} = \text{Rs } \frac{545 \times 3.14 \times 10}{100} = \text{Rs. } 171.13$$

Therefore, cost of metal sheet used to make the bucket is Rs 171.13.

